



Type 1+2+3 AC surge protector - 3-phase+N

CITEL

ZPAC1-8VG-PRO-SUM



- Type 1+2+3 AC Surge protection
- VG Technology
- For 40 mm busbar systems
- Iimp 8 kA (10/350 μs)
- Reduces energy costs: Does not produce flow current and leakage current
- Certified IEC 61643-11 and EN 61643-11

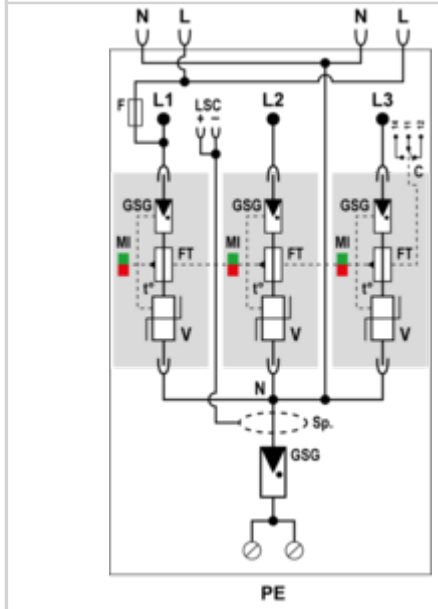
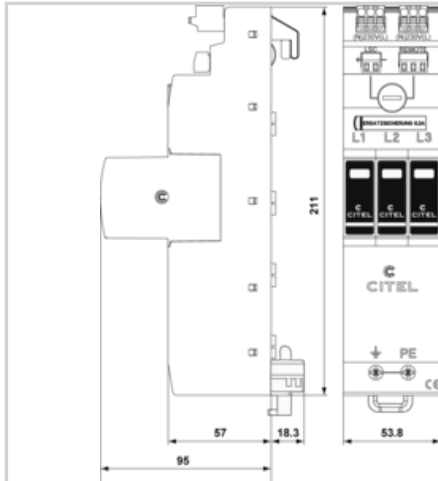

Electrical Characteristics

SPD type	1+2+3
Network	230/400 V 3-phase+N
AC system	TT-TNS
Nominal line voltage	Un 230/400 Vac
Max. AC operating voltage	Uc 275 Vac
Temporary Over Voltage (TOV) Characteristics - 5 sec. Without disconnection	UT 335 Vac withstand
Temporary Over Voltage (TOV) Characteristics - 120 mn Without disconnection or with safety disconnection	UT 440 Vac withstand
Temporary Over Voltage N/PE (TOV HT) Without disconnection or with safety disconnection	UT 1200 V/300A/200 ms withstand
Residual Current	Ipe None
Leakage current to Ground	Ipe None
Follow current	If None
Nominal discharge current 15 x 8/20 μs impulses	In 20 kA
Max. discharge current max. withstand @ 8/20 μs by pole	Imax 50 kA
Impulse current by pole max. withstand 10/350μs by pole	Iimp 8 kA
Total lightning current max. total withstand @ 10/350μs	Itotal 32 kA
Withstand on Combination waveform IEC 61643-11 Class III test: 1.2/50μs - 8/20μs	Uoc 6 kV
Withstand on overvoltages IEEE C62.41.1	20 kV
Specific energy by pole max. withstand 10/350 μs	W/R 16 kJ/ohm
Connection mode(s)	L/N and N/PE
Protection mode(s)	Common/Differential mode
Protection level L/N @ In (8/20μs)	Up L/N 1.5 kV
Protection level L/PE @ In (8/20μs)	Up L/PE 1.5 kV
Residual voltage L/N at 5 kA @ 5 kA (8/20μs)	Up-5kA 0.7 kV
Admissible short-circuit current	Iscrc 50 000 A

Mechanical Characteristics

Technology	VG Technology (MOV+GSG)
SPD configuration	3-phase+Neutral
Connection to Network	By 40mm busbar and wire for PE: 6-35mm ² (50mm ²)
Format	Plug-in modular box
Mounting	40 mm busbar systems
Housing material	Thermoplastic UL94 V-0
Operating temperature	Tu -40/+85°C
Protection rating	IP20
Failsafe mode	Disconnection from AC network
Disconnection indicator	1 mechanical indicator by pole
Spare module(s)	ZMDAC1-8VG-PRO-275
Remote signaling of disconnection	Output on changeover contact
Wiring for remote signaling	1.5 mm ² max.
Max. Voltage/Current for remote signaling	250 V / 0.5 A (AC) / 30 V / 2 A (DC)
Dimensions	See diagram
Weight	0.71 kg

Disconnectors

Thermal disconnector	Internal
Installation ground fault breaker	Type 'S' or delayed
Back-up protection device	max. 315 A (gL/gG)

Standards

ZPAC1-8VG-PRO-SUM

Standards compliance	IEC 61643-11 / EN 61643-11 / UL1449 4ed.
Certification	KEMA
Part number	64086