



CITEL

19" patch panel surge protector for high speed network STP

PL12-CAT6



- ↳ Surge protector for CAT6
- ↳ 12 ports
- ↳ 19" patch panel 1 U
- ↳ 100/1000/10Gigabit Ethernet network compliance
- ↳ Connectors RJ45 shielded
- ↳ Bi-directionnel

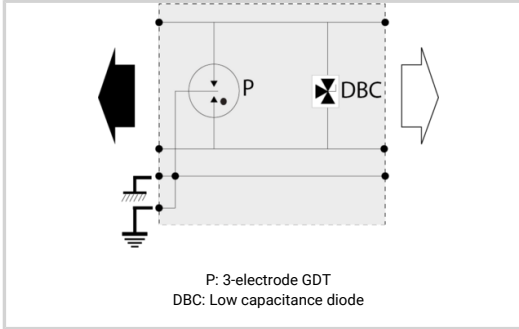

Electrical Characteristics		
Network		10 Gigabit Ethernet, Cat.6 cabling
Nominal line voltage	Un	5 Vdc
Max. DC operating voltage	Uc	8 Vdc
Max. frequency	f max.	250 MHz
Max. data rate		10/100/1000 Mbps
Insertion loss		< 1 dB
Max. load current @25°C	IL	1000 mA
Protection level @ In (8/20 μs)	Up L/L	20 V
Max. capacitance	C	< 25 pF
Impulse current 2 x 10/350μs Test - D1 Category	Iimp	500 A
Line/Line Nominal discharge current C2 Category	In L/L	500 A
Nominal Discharge Current, X-C (Line/Earth) 8/20μs Test x 10 - C2 Category	In L/PE	2000 A
Mechanical Characteristics		
Technology		GDT+Clamping diode
SPD configuration		12 ports de 8 wires
Connection to Network		RJ45 shielded female input/output
Format		Rack 19"
Mounting		Baie 19"
Housing material		Aluminium
Operating temperature	Tu	-40/+85°C
Protection rating		IP20
Failsafe mode		Short-circuit
Disconnection indicator		Transmission interrupt
Spare module(s)		12-port PCB
Remote signaling of disconnection		No
Pinout		(1-2)(3-6)(4-5)(7-8)
Dimensions		See diagram
Standards		
Standards compliance		IEC 61643-21 / EN 61643-21 / UL497 B / IEEE 802-3an
Part number		
581534		

