



CITEL

MLP2-230L-P/RS



Specially developed spd with combined protection for 2-phase power supply (control phase):

- Many variants available depending on application
- With screw terminals or cable wiring
- IP65 versions
- For protection class I or II application
- Developed for Uoc: 10 kV and I<sub>max</sub>: 10 kA for highest outdoor requirements according to IEEE & ANSI
- Optical error signalling

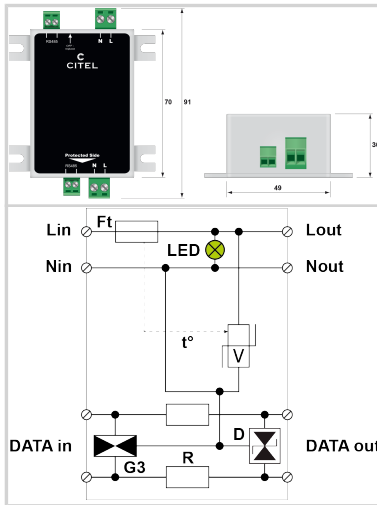

Electrical Characteristics		
SPD type	IEC	2+3
AC system		TT-TN
Nominal line voltage	Un	230-277 Vac
Max. AC operating voltage	Uc	305 Vac
Max. frequency	f max.	10 MHz
Max. load current @25°C	IL	2.5 A
Temporary Over Voltage (TOV) Characteristics - 5 sec. Without disconnection	UT	335 Vac withstand
Temporary Over Voltage (TOV) Characteristics - 120 mn Without disconnection or with safety disconnection	UT	440 Vac disconnection
Residual Current Leakage current to Ground	I <sub>pe</sub>	None
Follow current	I <sub>f</sub>	None
Nominal discharge current 15 x 8/20 μs impulses	I <sub>n</sub>	5 kA
Max. discharge current max. withstand @ 8/20 μs by pole	I <sub>max</sub>	10 kA
Total Maximum discharge current max. total withstand @ 8/20 μs	I <sub>max</sub> Total	20 kA
Withstand on Combination waveform IEC 61643-11 Class III test: 1.2/50μs - 8/20μs	Uoc	10 kV / 5 kA
Withstand on overvoltages IEEE C62.41.1		10 kV / 10 kA
Protection mode(s)		Common/Differential mode
Protection level L/N @ I <sub>n</sub> (8/20μs)	Up L/N	1.5 kV
Protection level L/PE @ I <sub>n</sub> (8/20μs)	Up L/PE	1.5 kV
Admissible short-circuit current	I <sub>sc</sub>	10 000 A
Mechanical Characteristics		
Mounting		Wall or plate
Housing material		Thermoplastic UL94 V-0
Operating temperature	Tu	-40/+85°C
Dimensions		See diagram
Disconnectors		
Thermal disconnector		Internal
Installation ground fault breaker		Type 'S' or delayed
Standards		
Standards compliance		IEC 61643-11 / EN 61643-11 / UL1449 ed.5
<b>Part number</b>		<b>721252</b>

