



# CITEL

## Type 1+2 AC surge protector single-phase

### DS132R-320



- ▶ Discover our latest innovation : the [DAC1-13-20-320](#)
- ▶ Type 1 + 2 AC multipolar surge protector
- ▶ In : 20 kA
- ▶ Iimp total : 25 kA
- ▶ Pluggable module for each phase
- ▶ Remote signaling (option)
- ▶ EN 61643-11, IEC 61643-11 compliance

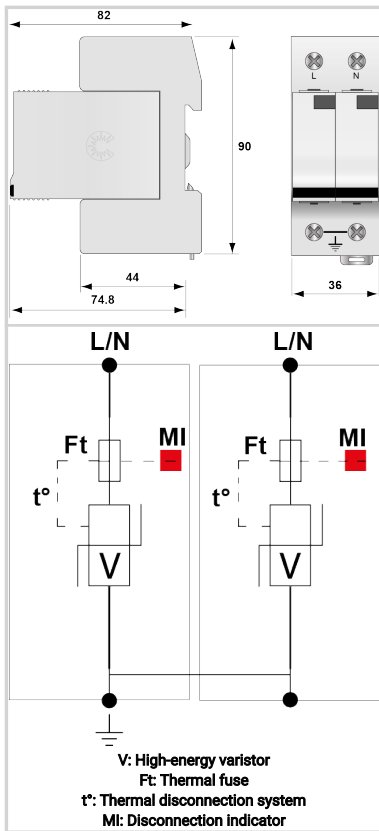

Electrical Characteristics		
SPD type	IEC	1+2
Network		230 V single-phase
AC system		TN
Nominal line voltage	Un	230 Vac
Max. AC operating voltage	Uc	320 Vac
Temporary Over Voltage (TOV) Characteristics - 5 sec. <i>Without disconnection</i>	UT	335 Vac withstand
Temporary Over Voltage (TOV) Characteristics - 120 mn <i>Without disconnection or with safety disconnection</i>	UT	440 Vac disconnection
Follow current	If	None
Nominal discharge current <i>15 x 8/20 μs impulses</i>	In	20 kA
Max. discharge current <i>max. withstand @ 8/20 μs by pole</i>	Imax	50 kA
Impulse current by pole <i>max. withstand 10/350μs by pole</i>	Iimp	12.5 kA
Total lightning current <i>max. withstand @ 10/350μs</i>	Itotal	25 kA
Withstand on overvoltages IEEE C62.41.1		20 kV
Specific energy by pole <i>max. withstand 10/350 μs</i>	W/R	40 kJ/ohm
Connection mode(s)		L/PE and N/PE
Protection mode(s)		Common mode
Protection level N/PE <i>@ In (8/20μs)</i>	Up N/PE	1.6 kV
Protection level L/PE <i>@ In (8/20μs)</i>	Up L/PE	1.6 kV
Admissible short-circuit current	Iscrr	25 000 A
Mechanical Characteristics		
Technology		MOV
SPD configuration		Single phase
Connection to Network		By screw terminals: 2.5-25mm <sup>2</sup> / by bus
Format		Plug-in modular box
Mounting		Symmetrical rail 35 mm (EN 60715)
Housing material		Thermoplastic UL94 V-0
Operating temperature	Tu	-40/+85°C
Protection rating		IP20
Failsafe mode		Disconnection from AC network
Disconnection indicator		1 mechanical indicator by pole
Spare module(s)		DSM130R-320
Remote signaling of disconnection		option : DS132RS-320: output on changeover contact
Dimensions		See diagram
Disconnectors		
Thermal disconnector		Internal
Installation ground fault breaker		Type 'S' or delayed
Back-up protection device		Fuses Type gG - 125 A
Standards		
Standards compliance		IEC 61643-11 / EN 61643-11 / UL1449 ed.5
Certification		
Part number		
<b>571902</b>		

