



CITEL

MLP1-230L-W/RS

Specially developed spd with combined protection for 2-phase power supply (control phase):

- Many variants available depending on application
- With screw terminals or cable wiring
- IP65 versions
- For protection class I or II application
- Developed for Uoc: 10 kV and I_{max}: 10 kA for highest outdoor requirements according to IEEE & ANSI
- Optical error signalling

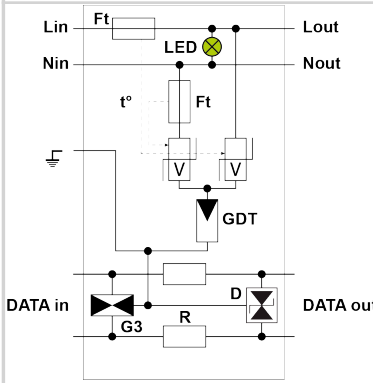
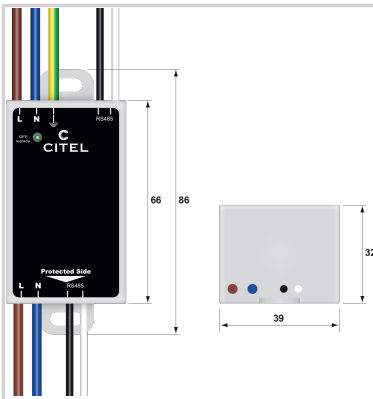
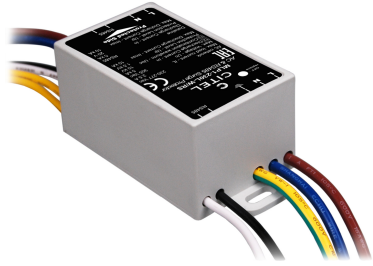

Electrical Characteristics		
SPD type	IEC	2+3
Network		220-240 V Single-phase
AC system		TT-TN
Nominal line voltage	Un	230-277 Vac
Max. AC operating voltage	Uc	305 Vac
Max. frequency	f max.	10 MHz
Max. load current @25°C	IL	2.5 A
Temporary Over Voltage (TOV) Characteristics - 5 sec. Without disconnection	UT	335 Vac withstand
Temporary Over Voltage (TOV) Characteristics - 120 mn Without disconnection or with safety disconnection	UT	440 Vac disconnection
Residual Current	Ipe	None
Leakage current to Ground		
Follow current	If	None
Nominal discharge current 15 x 8/20 μs impulses	In	5 kA
Max. discharge current max. withstand @ 8/20 μs by pole	I _{max}	10 kA
Total Maximum discharge current max. total withstand @ 8/20 μs	I _{max} Total	20 kA
Withstand on Combination waveform IEC 61643-11 Class III test: 1.2/50μs - 8/20μs	Uoc	10 kV / 5 kA
Withstand on overvoltages IEEE C62.41.1		10 kV / 10 kA
Protection level L/N @ In (8/20μs)	Up L/N	1.5 kV
Protection level L/PE @ In (8/20μs)	Up L/PE	1.5 kV
Admissible short-circuit current	I _{sc}	10 000 A
Mechanical Characteristics		
Technology		MOV+GDT
Mounting		Wall or plate
Housing material		Thermoplastic UL94 V-0
Operating temperature	Tu	-40/+85°C
Protection rating		IP20
Failsafe mode		Disconnection and AC line cut-off
Disconnection indicator		LED green OFF and AC network cut-off
Operating indicator		Green led(s) on
Remote signaling of disconnection		No
Dimensions		See diagram
Disconnectors		
Thermal disconnector		Internal
Installation ground fault breaker		Type 'S' or delayed
Standards		
Standards compliance		IEC 61643-11 / EN 61643-11 / UL1449 ed.5
Part number		
711251		

