



CITEL



Type 2+3 AC surge protector -2-pole - Monobloc

DACN30VGS-20-1260

- ▶ Type 2 + 3 AC surge protector
- ▶ VG Technology
- ▶ In: 15 kA
- ▶ No leakage current
- ▶ Monobloc module for each phase
- ▶ Remote signaling
- ▶ Optimized to TOV
- ▶ EN 61643-11, IEC 61643-11 and UL1449 ed.5 compliance

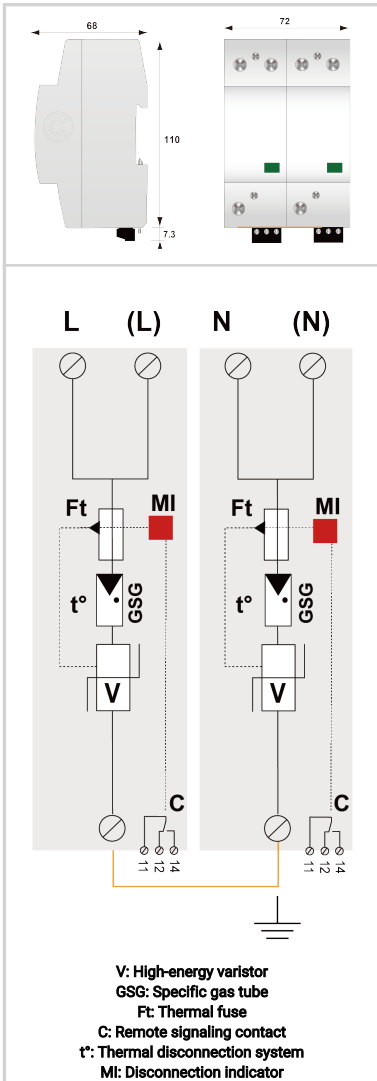

Electrical Characteristics		
SPD type	IEC	2+3
Nominal line voltage	Un	1140 Vac
Max. AC operating voltage	Uc	1260 Vac
Max. load current @25°C	IL	100 A
Temporary Over Voltage (TOV) Characteristics - 5 sec. Without disconnection	UT	1650 Vac withstand
Temporary Over Voltage (TOV) Characteristics - 120 mn Without disconnection or with safety disconnection	UT	2200 Vac disconnection
Residual Current Leakage current to Ground	Ipe	None
Follow current	If	None
Nominal discharge current 15 x 8/20 μs impulses	In	15 kA
Max. discharge current max. withstand @ 8/20 μs by pole	I _{max}	30 kA
Withstand on Combination waveform IEC 61643-11 Class III test: 1.2/50μs - 8/20μs	Uoc	6 kV
Protection level @ In (8/20μs)	Up	4.0 kV
Protection level @ In (8/20μs) and @ 6 kV (1,2/50 μs)	Up	5.0 kV
Residual voltage at 5 kA @ 5 kA (8/20μs)	Up-5kA	3.2 kV
Admissible short-circuit current	Iscrr	25 000 A
Mechanical Characteristics		
Technology		VG Technology (MOV+GSG)
SPD configuration		Single phase
Connection to Network		By screw terminals: 2.5-25mm ² (35mm ² rigid)
Format		Monobloc modular box
Mounting		Symmetrical rail 35 mm (EN 60715)
Housing material		Thermoplastic UL94 V-0
Operating temperature	Tu	-40/+85°C
Protection rating		IP20
Failsafe mode		Disconnection from AC network
Disconnection indicator		1 mechanical indicator - Red/Green
Remote signaling of disconnection		Output on changeover contact
Wiring for remote signaling		1.5 mm ² max.
Max. Voltage/Current for remote signaling		250 V / 0.5 A (AC) / 30 V / 3 A (DC)
Dimensions		See diagram - 4TE (EN43880)
Disconnectors		
Thermal disconnector		Internal
Installation ground fault breaker		Type 'S' or delayed
Back-up protection device		Fuses type gG - 50 A
Standards		
Standards compliance		IEC 61643-11 / EN 61643-11 / UL1449 ed.5
Part number		
29422032		

