



CITEL

ZPAC1-8VG-PRO-SU



- Type 1+2+3 combined SPD based on a gas-filled spark gap
- 10-year guarantee
- Discharge capacity per pole: $I_{imp} = 8 \text{ kA}$ (10/350 μs)
- Operating and leakage current-free
- Individually pluggable protection modules: sustainable solution, cost-effective maintenance
- Complies with the IEC 61643-11 and EN 61643-11 standards
- VDE-AR-N 4100 compliant "Use of surge protective devices (SPD) type 1 in main power supply systems"
- Integrated fuse
- Dual voltage tap for RFZ and APZ
- Potential-free remote signaling contact



Electrical Characteristics		
SPD type	IEC	1+2+3
Network		230/400 V 3-phase+N
AC system		TT-TNS
Nominal line voltage	Un	230/400 Vac
Max. AC operating voltage	Uc	275 Vac
Temporary Over Voltage (TOV) Characteristics - 5 sec. Without disconnection	UT	335 Vac withstand
Temporary Over Voltage (TOV) Characteristics - 120 mn Without disconnection or with safety disconnection	UT	440 Vac withstand
Temporary Over Voltage N/PE (TOV HT) Without disconnection or with safety disconnection	UT	1200 V/300A/200 ms withstand
Residual Current		
Leakage current to Ground	Ipe	None
Follow current	If	None
Nominal discharge current 15 x 8/20 μs impulses	In	20 kA
Max. discharge current max. withstand @ 8/20 μs by pole	I _{max}	50 kA
Impulse current by pole max. withstand 10/350 μs by pole	I _{imp}	8 kA
Total lightning current max. total withstand @ 10/350 μs	I _{total}	32 kA
Withstand on Combination waveform IEC 61643-11 Class III test: 1.2/50 μs - 8/20 μs	Uoc	6 kV
Withstand on overvoltages IEEE C62.41.1		20 kV
Specific energy by pole max. withstand 10/350 μs	W/R	16 kJ/ohm
Connection mode(s)		L/N and N/PE
Protection mode(s)		Common/Differential mode
Protection level L/N @ In (8/20 μs)	Up L/N	1.5 kV
Protection level L/PE @ In (8/20 μs)	Up L/PE	1.5 kV
Residual voltage L/N at 5 kA @ 5 kA (8/20 μs)	Up-5kA	0.7 kV
Admissible short-circuit current	I _{scrr}	50 000 A
Mechanical Characteristics		
Technology		VG Technology (MOV+GSG)
SPD configuration		3-phase+Neutral
Connection to Network		By 40mm busbar and wire for PE: 6-35mm ² (50mm ²)
Format		Plug-in modular box
Mounting		40 mm busbar systems
Housing material		Thermoplastic UL94 V-0
Operating temperature	Tu	-40/+85°C
Protection rating		IP20
Failsafe mode		Disconnection from AC network



CITEL

ZPAC1-8VG-PRO-SU

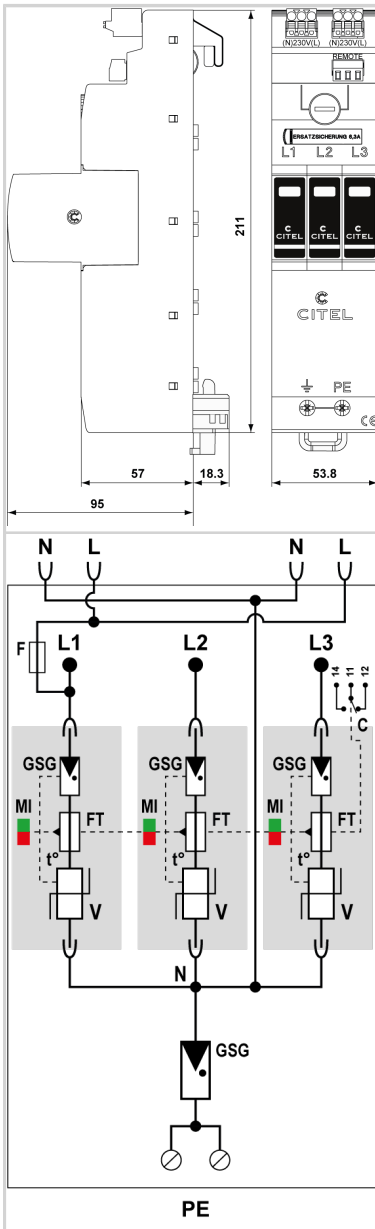

Disconnection indicator	1 mechanical indicator by pole
Spare module(s)	MDAC1-8VG-275
Remote signaling of disconnection	Output on changeover contact
Wiring for remote signaling	1.5 mm ² max.
Max. Voltage/Current for remote signaling	250 V / 0.5 A (AC) / 30 V / 2 A (DC)
Dimensions	See diagram
Disconnectors	
Thermal disconnector	Internal
Installation ground fault breaker	Type 'S' or delayed
Back-up protection device	max. 315 A (gL/gG)
Standards	
Standards compliance	IEC 61643-11 / EN 61643-11 / UL1449 5ed.
Certification	KEMA
Part number	
64085	

