



CITEL

Compact Type 2 (or 3) DC surge protector - 30 V - Monobloc

DDCN03S-21YG-30



- DC Power Type 2 (or 3) SPD
- 2-port configuration (series mounting)
- Compact and Cost effective
- In/Imax: 1.5 kA/ 3 kA
- Max. load current: 25A
- Disconnection
- Remote signaling
- EN 61643-11, IEC 61643-11 compliance



Electrical Characteristics		
Nominal DC voltage	Un-dc	24 Vdc
Max. DC operating voltage	Uc	30 Vdc
Max. load current @25°C	IL	25 A
Residual Current <i>Leakage current to Ground</i>	Ipe	None
Nominal discharge current <i>15 x 8/20 μs impulses</i>	In	1.5 kA
Max. discharge current <i>max. withstand @ 8/20 μs by pole</i>	Imax	3 kA
Withstand on Combination waveform IEC 61643-11 <i>Class III test: 1.2/50μs - 8/20μs</i>	Uoc	3 kV
Connection mode(s)		+/-PE
Protection level +/- <i>@ In (8/20μs)</i>	Up	0.2 kV
Protection level +/-PE (-/PE) <i>@ In (8/20μs)</i>	Up	0.8 kV
Admissible short-circuit current	Iscrc	10 000 A
Mechanical Characteristics		
Connection to Network		By screw terminals: 1.5-10mm ²
Mounting		Symmetrical rail 35 mm (EN 60715)
Housing material		Thermoplastic UL94 V-0
Operating temperature	Tu	-40/+85°C
Protection rating		IP20
Failsafe mode		Disconnection from DC network
Disconnection indicator		Green LED OFF
Remote signaling of disconnection		output on NC contact
Dimensions		See diagram - 1TE (EN43880)
Disconnectors		
Thermal disconnector		Internal
Back-up protection device		Fuses type gG - 25A
Standards		
Standards compliance		IEC 61643-11 / prIEC 61643-41
Part number		
70124042		



CITEL

DDCN03S-21YG-30

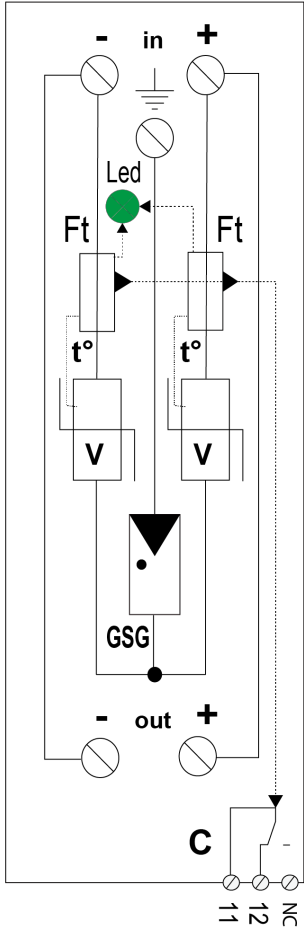
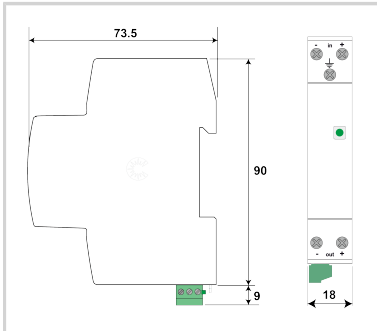

V: High-energy varistor
 GSG: Specific Gas Tube
 LED: Disconnection Indicator
 Ft: Thermal fuse
 t°: Thermal disconnection system
 C: Remote signaling contact

