

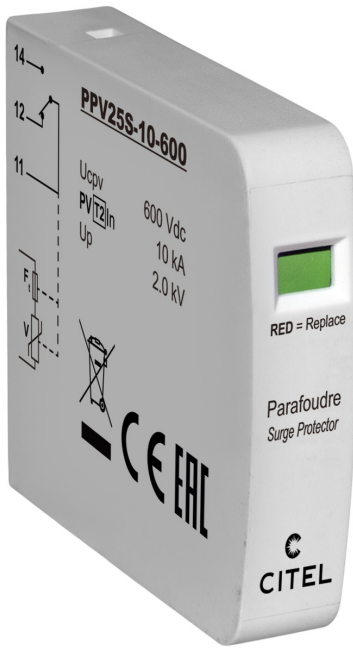

CITEL

Type 2 PV Surge Protector for PCB mounting

PPV25S-10-600



- Type 2 surge protector for Photovoltaic
- PCB mounting
- I_{max}: 25 kA
- Remote signaling
- EN 50539-11 and IEC 61643-31 compliance*

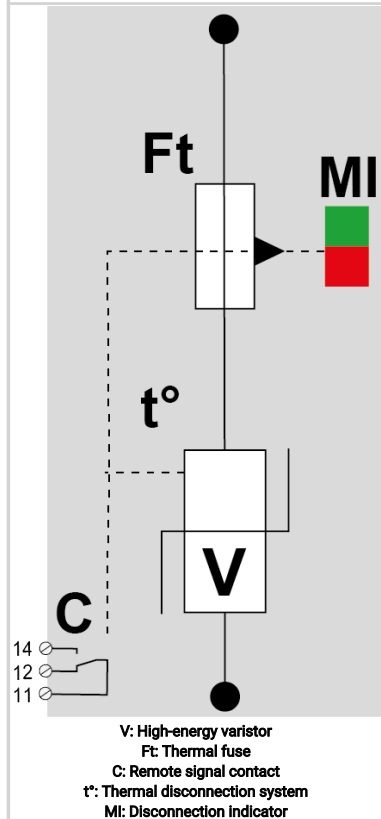
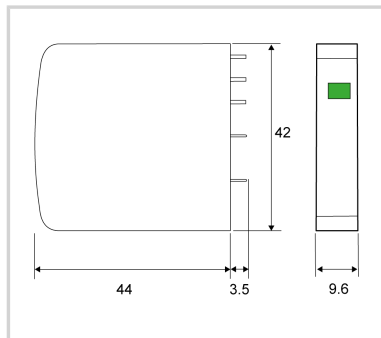

Electrical Characteristics

SPD type	IEC	2
Max. PV operating voltage	Ucpv	600 Vdc
Max. PV operating voltage (star mounting)	Ucpv	1200 Vdc
PV Permanent Operating current Current consumption at Ucpv	Icpv	< 0.1 mA
Nominal discharge current 15 x 8/20 μs impulses	In	10 kA
Max. discharge current max. withstand @ 8/20 μs by pole	I _{max}	25 kA
Current withstand short circuit PV	Iscpv	15 000 A
Protection level @ In (8/20μs)	Up	2 kV
Protection level (star mounting) (+/-) / (+/PE or -/PE) @ In (8/20μs)	Up	4 kV

Mechanical Characteristics

Technology		MOV
Connection to Network		Through soldering pins
Mounting		On Printed Circuit Board
Housing material		Thermoplastic UL94 V-0
Operating temperature	Tu	-40/+85°C
Protection rating		IP20
Disconnection indicator		1 mechanical indicator
Remote signaling of disconnection		Output on changeover contact
Dimensions		See diagram

Disconnectors

Thermal disconnector		Internal
Back-up protection device		Without

Standards

Standards compliance		IEC 61643-31 / EN 50539-11 *The standard cover devices. PPV /PAC series are components. Compliant when combined is an assembly.
----------------------	--	---------------------------------------------------------------------------------------------------------------------------------

Part number

8721203

