



CITEL

Type 1+2 AC surge protector - 3-phase

DAC1-13VGS-30-320



- ▶ Type 1 + 2 + 3 AC surge protector
- ▶ VG Technology
- ▶ In : 20 kA
- ▶ Iimp : 12,5 kA on 10/350µs impulse
- ▶ No leakage current
- ▶ Pluggable module for each phase
- ▶ Remote signaling
- ▶ Optimized to TOV
- ▶ EN 61643-11, IEC 61643-11 and UL1449 ed.5 compliance
- ▶ Certified EN 61643-11 and IEC 61643-11

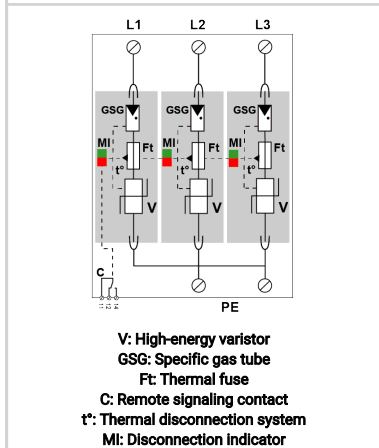
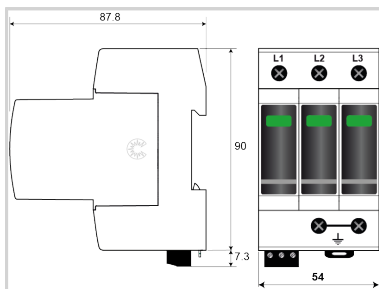

Electrical Characteristics

SPD type	IEC	1+2+3
Network		230/400 V 3-phase
AC system		TNC
Max. AC operating voltage	Uc	320 Vac
Temporary Over Voltage (TOV) Characteristics - 5 sec. <i>Without disconnection</i>	UT	335 Vac withstand
Temporary Over Voltage (TOV) Characteristics - 120 mn <i>Without disconnection or with safety disconnection</i>	UT	440 Vac withstand
Residual Current	Ipe	None
Leakage current to Ground		
Follow current	If	None
Nominal discharge current <i>15 x 8/20 µs impulses</i>	In	20 kA
Max. discharge current <i>max. withstand @ 8/20 µs by pole</i>	I _{max}	50 kA
Total Maximum discharge current <i>max. total withstand @ 8/20 µs</i>	I _{max} Total	150 kA
Impulse current by pole <i>max. withstand 10/350µs by pole</i>	Iimp	12.5 kA
Impulse current N/PE <i>max. withstand 10/350µs</i>	Iimp N /PE	50 kA
Total lightning current <i>max. total withstand @ 10/350µs</i>	I _{total}	37.5 kA
Withstand on Combination waveform IEC 61643-11 <i>Class III test: 1.2/50µs - 8/20µs</i>	Uoc	6 kV
Specific energy by pole <i>max. withstand 10/350 µs</i>	W/R	40 kJ/ohm
Protection mode(s)		L/PE
Protection level L/PE <i>@ In (8/20µs) and @ 6 kV (1,2/50 µs)</i>	L/PE	1.5 kV
Residual voltage L/PE at 5 kA <i>@ 5 kA (8/20µs)</i>	Up-5kA	0.9 kV
Admissible short-circuit current	Iscrr	50 000 A

Mechanical Characteristics

Technology		VG Technology (MOV+GSG)
SPD configuration		3-phase
Connection to Network		By screw terminals: 2.5-25mm ² (35mm ² rigid)
Format		Plug-in modular box
Mounting		Symmetrical rail 35 mm (EN 60715)
Housing material		Thermoplastic UL94 V-0
Operating temperature	Tu	-40/+85°C
Protection rating		IP20
Failsafe mode		Disconnection from AC network
Disconnection indicator		1 mechanical indicator by pole - Red/Green
Spare module(s)		MDAC1-13VG-320
Remote signaling of disconnection		output on changeover contact
Wiring for remote signaling		1.5 mm ² max.
Max. Voltage/Current for remote signaling		250 V / 0.5 A (AC) / 30 V / 3 A (DC)
Dimensions		See diagram - 3 TE (EN43880)

Disconnectors

Thermal disconnector		Internal
Installation ground fault breaker		Type 'S' or delayed
Back-up protection device		Fuse assembly: SFD1-13S-30 / or 125 A min. - 315 A max. - Fuses Type gG

Standards

Standards compliance		IEC 61643-11 / EN 61643-11 / UL1449 ed.5
Certification		KEMA



CITEL

Type 1+2 AC surge protector - 3-phase

DAC1-13VGS-30-320

Part number

821730323

