

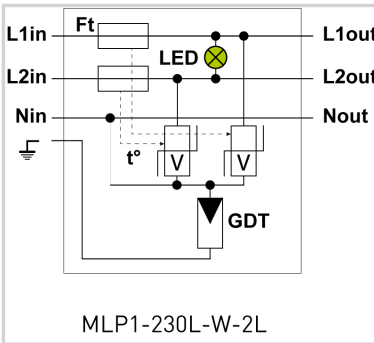

MLP1-230L-W-2L

Specially developed spd with combined protection for 2-phase power supply (control phase):

- Many variants available depending on application
- With screw terminals or cable wiring
- IP65 versions
- For protection class I or II application
- Developed for Uoc: 10 kV and Imax: 10 kA for highest outdoor requirements according to IEEE & ANSI
- Optical error signalling



Electrical Characteristics			
SPD type	IEC	2+3	
Network		220-240 V Single-phase	
AC system		TT-TN	
Nominal line voltage	Un	230-277 Vac	
Max. AC operating voltage	Uc	305 Vac	
Max. frequency	f max.	10 MHz	
Max. load current @25°C	IL	2.5 A	
Temporary Over Voltage (TOV) Characteristics - 5 sec. Without disconnection	UT	335 Vac withstand	
Temporary Over Voltage (TOV) Characteristics - 120 mn Without disconnection or with safety disconnection	UT	440 Vac disconnection	
Residual Current Leakage current to Ground	Ipe	None	
Follow current	If	None	
Nominal discharge current 15 x 8/20 μs impulses	In	5 kA	
Max. discharge current max. withstand @ 8/20 μs by pole	Imax	10 kA	
Total Maximum discharge current max. total withstand @ 8/20 μs	Imax Total	20 kA	
Withstand on Combination waveform IEC 61643-11 Class III test: 1.2/50μs - 8/20μs	Uoc	10 kV / 5 kA	
Withstand on overvoltages IEEE C62.41.1		10 kV / 10 kA	
Protection mode(s)		Common/Differential mode	
Protection level L/N @ In (8/20μs)	Up L/N	1.5 kV	
Protection level L/PE @ In (8/20μs)	Up L/PE	1.5 kV	
Admissible short-circuit current	Iscrc	10 000 A	
Mechanical Characteristics			
Technology		MOV+GDT	
Connection to Network		By screw terminal: 1.5mm <sup>2</sup> max.	
Mounting		On plate	
Housing material		Thermoplastic UL94 V-0	
Operating temperature	Tu	-40/+85°C	
Protection rating		IP65	
Failsafe mode		Disconnection and AC line cut-off	
Disconnection indicator		LED green OFF and AC network cut-off	
Operating indicator		Green Led ON	
Remote signaling of disconnection		No	
Dimensions		See diagram	
Disconnectors			
Thermal disconnector		Internal	
Installation ground fault breaker		Type 'S' or delayed	
Standards			
Standards compliance		IEC 61643-11 / EN 61643-11 / UL1449 ed.5	
Part number			
<b>731211</b>			

