



CITEL

Type 1+2 AC surge protector - 3-phase+N

DS504E-320



- ▶ Type 1 + 2 multipolar AC surge protector
- ▶ Iimp total : 200 kA (10/350µs impulse)
- ▶ Imax : 200 kA (8/20µs impulse)
- ▶ Internal disconnections, status indicator and remote signaling
- ▶ Conforme NF EN 61643-11, IEC 61643-11, UL1449 ed.5

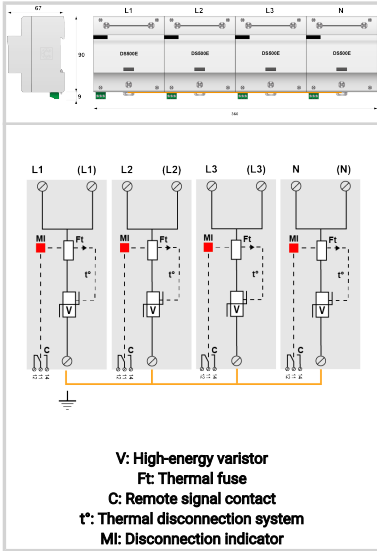

Electrical Characteristics		
SPD type	IEC	1+2
Network		230/400 V 3-phase+N
AC system		TNS
Nominal line voltage	Un	230 Vac
Max. AC operating voltage	Uc	320 Vac
Max. load current <i>if series connection</i>	IL	100 A
Temporary Over Voltage (TOV) Characteristics - 5 sec. <i>Without disconnection</i>	UT	335 Vac withstand
Temporary Over Voltage (TOV) Characteristics - 120 mn <i>Without disconnection or with safety disconnection</i>	UT	440 Vac disconnection
Follow current	If	None
Nominal discharge current <i>15 x 8/20 µs impulses</i>	In	50 kA
Max. discharge current <i>max. withstand @ 8/20 µs by pole</i>	I _{max}	200 kA
Impulse current by pole <i>max. withstand 10/350µs by pole</i>	I _{imp}	50 kA
Total lightning current <i>max. total withstand @ 10/350µs</i>	I _{total}	200 kA
Specific energy by pole <i>max. withstand 10/350 µs</i>	W/R	156 kJ/ohm
Connection mode(s)		L/PE and N/PE
Protection mode(s)		Common mode
Protection level N/PE <i>@ In (8/20µs)</i>	Up N/PE	1.8 kV
Protection level L/PE <i>@ In (8/20µs)</i>	Up L/PE	1.8 kV
Protection level N/PE at 5 kA <i>@ 5 kA (8/20µs)</i>	Up-5kA	1.2 kV
Residual voltage L/PE at 5 kA <i>@ 5 kA (8/20µs)</i>	Up-5kA	1.2 kV
Admissible short-circuit current	I _{sc}	50 000 A
Mechanical Characteristics		
Technology		MOV
SPD configuration		3-phase
Connection to Network		By screw terminals: 6-35mm ² / by bus
Format		1-pole modular box assembled
Mounting		Symmetrical rail 35 mm (EN 60715)
Housing material		Thermoplastic UL94 V-0
Operating temperature	Tu	-40/+85°C
Protection rating		IP20
Failsafe mode		Disconnection from AC network
Disconnection indicator		1 mechanical indicator by pole
Remote signaling of disconnection		Output on changeover contact
Dimensions		See diagram
Disconnectors		
Thermal disconnector		Internal
Installation ground fault breaker		Type 'S' or delayed
Back-up protection device		Fuses Type gG - 500 A
Standards		
Standards compliance		IEC 61643-11 / EN 61643-11 / UL1449 ed.5
Certification		
Part number		
504320		

