

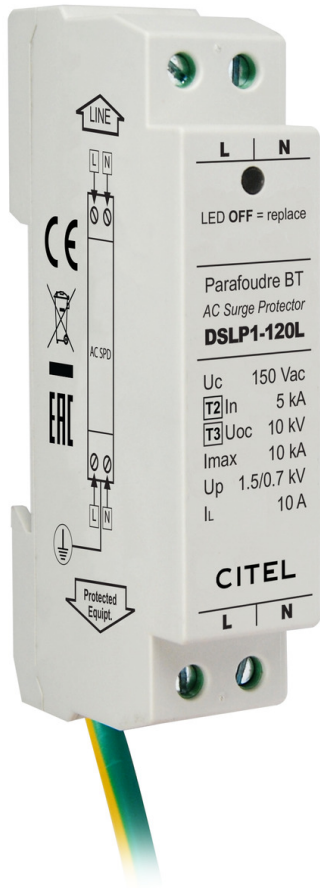

CITEL

Surge protector for LED lighting system Class 1

DSLSP1-120L



- Type 2 (or 3) surge protectors for LED
- Very compact (low profile)
- DIN rail mounting
- Screw terminal connection
- Status indicator
- Disconnection AC end of life
- EN 61643-11, IEC 61643-11 compliance

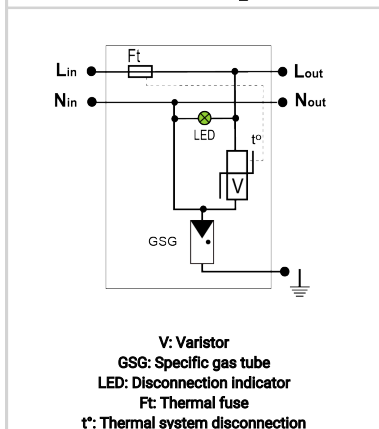
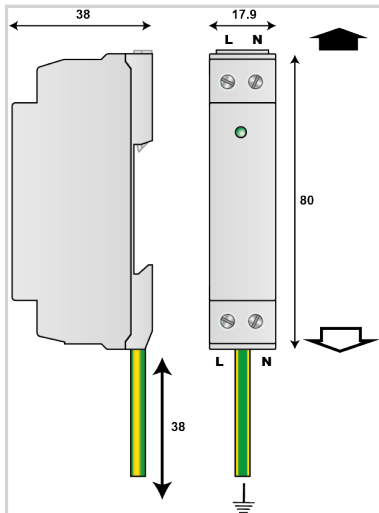

Electrical Characteristics

SPD type	IEC	2+3
Network		120 V single-phase
AC system		TT-TN
Nominal line voltage	Un	120 Vac
Max. AC operating voltage	Uc	150 Vac
Max. load current @25°C	IL	10 A
Temporary Over Voltage (TOV) Characteristics - 5 sec. Without disconnection	UT	180 Vac withstand
Temporary Over Voltage (TOV) Characteristics - 120 mn Without disconnection or with safety disconnection	UT	230 Vac disconnection
Temporary Over Voltage N/PE (TOV HT) Without disconnection or with safety disconnection	UT	1200 V/300A/200 ms disconnection
Residual Current Leakage current to Ground	Ipe	None
Nominal discharge current 15 x 8/20 μs impulses	In	5 kA
Max. discharge current max. withstand @ 8/20 μs by pole	I _{max}	10 kA
Withstand on Combination waveform IEC 61643-11 Class III test: 1.2/50μs - 8/20μs	Uoc	10 kV / 5 kA
Withstand on overvoltages IEEE C62.41.1		10 kV / 10 kA
Protection mode(s)		Common/Differential mode
Protection level L/N @ In (8/20μs)	Up L/N	0.7 kV
Protection level N/PE @ In (8/20μs)	Up N/PE	1.5 kV
Admissible short-circuit current	I _{scrr}	10 000 A

Mechanical Characteristics

Technology		MOV+GDT
Connection to Network		Screw terminal 2.5 mm ² max. Earthing conductor 2 mm ² - length 60 cm
Mounting		Symmetrical rail 35 mm (EN 60715)
Housing material		Thermoplastic UL94 V-0
Operating temperature	Tu	-40/+85°C
Protection rating		IP20
Failsafe mode		Disconnection from AC network
Disconnection indicator		LED green OFF and AC network cut-off
Operating indicator		Green Led ON
Dimensions		See diagram



CITEL

Surge protector for LED lighting system Class 1

DSLPL1-120L

Disconnectors	
Thermal disconnecter	Internal
Installation ground fault breaker	Type 'S' or delayed
Standards	
Standards compliance	EN 61643-11 / IEC 61643-11
Certification	CB
Part number	
352912	

